

Instructions



020-2369-00

TLA72X & TLA7XM Benchtop Mainframe Rackmount Installation

071-0897-00

Warning

The servicing instructions are for use by qualified personnel only. To avoid personal injury, do not perform any servicing unless you are qualified to do so. Refer to all safety summaries prior to performing service.

www.tektronix.com



071089700

Copyright © Tektronix, Inc. All rights reserved.

Tektronix products are covered by U.S. and foreign patents, issued and pending. Information in this publication supercedes that in all previously published material. Specifications and price change privileges reserved.

Tektronix, Inc., P.O. Box 500, Beaverton, OR 97077

TEKTRONIX and TEK are registered trademarks of Tektronix, Inc.



Table of Contents

General Safety Summary	ii
Service Safety Summary	iii
Installation Instructions	1
Install the Rackmount Kit Hardware	1
Install the Mainframe in the Rack	3
Replaceable Parts	9
Parts Ordering Information	9
Using the Replaceable Parts List	10

General Safety Summary

Review the following safety precautions to avoid injury and prevent damage to this product or any products connected to it. To avoid potential hazards, use this product only as specified.

Only qualified personnel should perform service procedures.

While using this product, you may need to access other parts of the system. Read the *General Safety Summary* in other system manuals for warnings and cautions related to operating the system.

Provide Proper Ventilation. Refer to the manual's installation instructions for details on installing the product so it has proper ventilation.

Symbols and Terms

Terms in this Manual. These terms may appear in this manual:



WARNING. Warning statements identify conditions or practices that could result in injury or loss of life.



CAUTION. Caution statements identify conditions or practices that could result in damage to this product or other property.

Terms on the Product. These terms may appear on the product:

DANGER indicates an injury hazard immediately accessible as you read the marking.

WARNING indicates an injury hazard not immediately accessible as you read the marking.

CAUTION indicates a hazard to property including the product.

Symbols on the Product. The following symbols may appear on the product:



Service Safety Summary

Only qualified personnel should perform service procedures. Read this *Service Safety Summary* and the *General Safety Summary* before performing any service procedures.

Do Not Service Alone. Do not perform internal service or adjustments of this product unless another person capable of rendering first aid and resuscitation is present.

Disconnect Power. To avoid electric shock, switch off the instrument power, then disconnect the power cord from the mains power.

Use Care When Servicing With Power On. Dangerous voltages or currents may exist in this product. Disconnect power, remove battery (if applicable), and disconnect test leads before removing protective panels, soldering, or replacing components.

To avoid electric shock, do not touch exposed connections.

To avoid potential hazards, use this product only as specified.

To prevent the instrument and rack from falling onto the operator, use two or more people to install the instrument into the rack cabinet. After completing the installation procedure, verify that the instrument and the rack cabinet will not tip forward while the instrument is extended out of the rack.

Installation Instructions

These instructions provide information for installing the 020-2369-00 TLA72X and TLA7XM Benchtop Mainframe Rackmount kit. Refer to *Site Considerations* in the Getting Started chapter of the *Tektronix Logic Analyzer Family User Manual* for cooling clearance information.

You can install the rackmount kit to either recess the mainframe into the front of mainframe rack or to extend it out of the front of the mainframe rack.

The steps for installing the rackmount kits consist of installing the rackmount hardware to the mainframe, and then installing the mainframe in the rack.

You will need the following tools to install the rackmount options:

- T-15 Torx driver
- T-20 Torx driver
- #2 Phillips screwdriver



WARNING. *Because of the size and weight of the mainframe, use care when lifting or moving the mainframe to avoid personal injury while performing the installation procedures. Use two people to lift or move the mainframe.*

Install the Rackmount Kit Hardware

Refer to Figure 1 and perform the following steps to install the rackmount kit hardware:

1. Remove the rubber feet from the mainframe.
2. Determine where you want the mainframe positioned in the rack (recessed inside the rack or protruding in front of the rack).

If you want the mainframe installed protruding in front of the rack, position the rackmount bracket as shown on the right side of Figure 1. If you want to recess the mainframe in the rack, position the rackmount bracket as shown on the left side of Figure 1.

3. Determine how far you want to recess or extend the mainframe and install the rackmount adapter as shown using two 8-32 screws (included with the kit). Repeat this step for the other bracket.

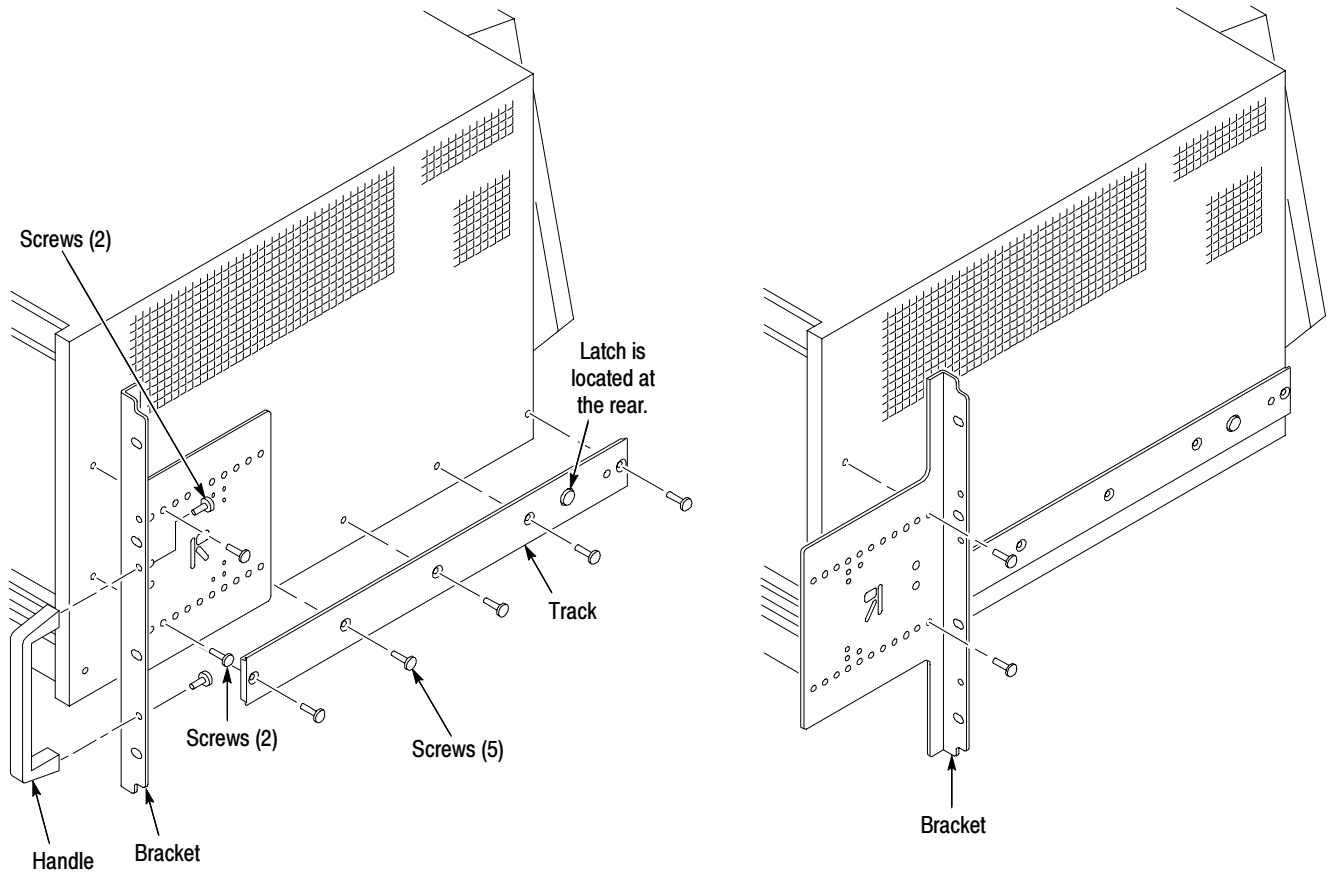

Figure 1: Installing the rackmount kit hardware

4. Remove the five 8-32 screws from both sides of the mainframe.
5. Attach the left and right inside tracks to the sides of the mainframe using five 8-32 flathead screws. Add a spacer plate between the left track and mainframe (refer to item 8 in Figure 6 on page 13). Orient the button latch so that it faces away from the mainframe and toward the rear.

Install the Mainframe in the Rack

1. Identify the right and left slide-out track assemblies: find the date code label on each assembly. The assembly to be mounted in the left side of the rack (the side nearest the left side of the mainframe when it is mounted in the rack) has a date code that ends with LH (for left hand). The right assembly has a date code ending with RH.
2. Measure the distance between the front and rear rail of the rack.
3. Align the rear bracket to the right slide-out track as shown in Figure 2. Note that the rear bracket has two pairs of mount-through holes. When aligning the bracket and the track, select a pair of holes that mount the rear bracket so the flange-to-flange distance (see Figure 2) matches the front rail to rear rail spacing that you just measured in step 2.

NOTE. If necessary, refer to the rackmount kit instructions for detailed installation information.

4. Attach the rear bracket to the right slide-out track using two 10-32 screws and a bar nut as shown in Figure 2. Leave the screws loose so that you can adjust the overall length of the slide-out track assembly when installing the mainframe in the rack. Use the extended length brackets to comply with deeper rackmounts.
5. Repeat steps 3 and 4 to assemble the left slide-out track assembly.

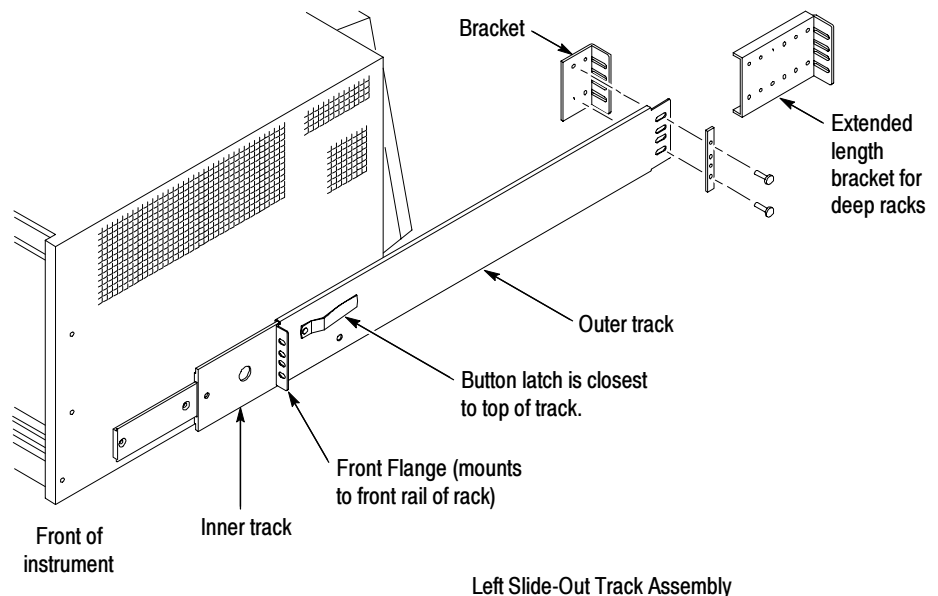

Figure 2: Assembling the slide-out track assemblies

6. Select the mounting position in the rack: select two 0.5-inch spaced holes in the front rail and verify that the 1.5-inch and 13.25-inch clearances exist relative to the mounting holes as shown in Figure 3.

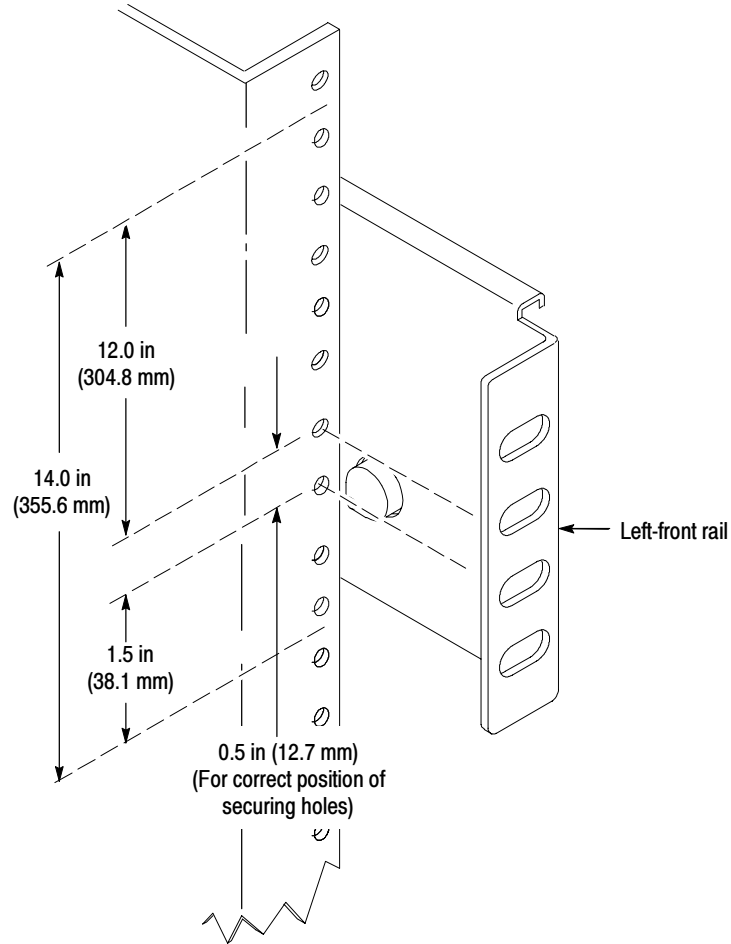

Figure 3: Vertical clearance for rack installation (standard mainframe)

7. Select the mounting method according to the rack type.

To mount the slide-out tracks with the front and rear flanges outside of the front and rear rails, use method A shown in Figure 4 when doing step 8. Add a bar nut to the installation only if the rails have untapped holes.

To mount with front and rear flanges inside of the rails, use mounting method B shown in Figure 4 when doing step 8. This mounting method assumes untapped holes.

8. Using the mounting method determined from the previous step, secure the right slide-out track assembly to the front and rear rails. Seat the screws fully, but lightly, so that you can adjust the mounting later.
9. Tighten the screws left loose in step 4 to fix the front to rear flange spacing of the slide-out track assembly.
10. Repeat steps 6 through 9 to mount the left slide-out track assembly.

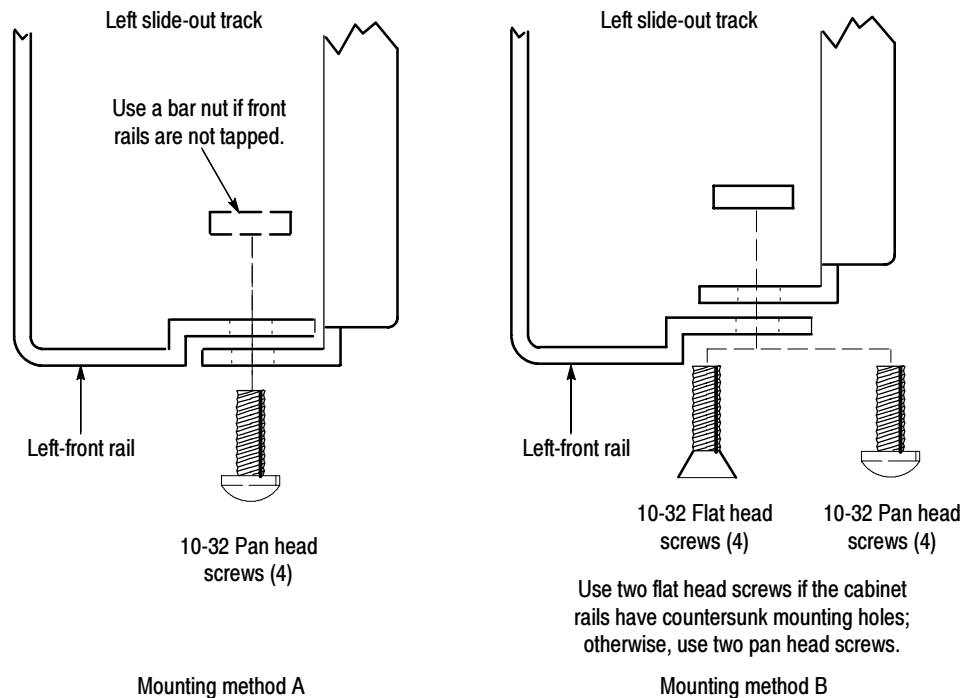

Figure 4: Installing the slide-out track assemblies in the rack (Top view)



WARNING. Because of the size and weight of the mainframe, installing the mainframe alone can result in personal injury or equipment damage. Installing the mainframe in the rack requires at least two people. One person should be on the left side of the mainframe with one hand holding the left front handle and with the other hand underneath the mainframe. The other person should do likewise on the right side of the mainframe.

11. Fully extend the inner tracks of each slide-out section out of the front of the rack until they lock.



WARNING. *To prevent the mainframe from tipping or dropping during installation, two or more people should install the mainframe into the cabinet.*

After completing the installation, verify that the mainframe and the cabinet will not tip forward when the mainframe is in the fully extended position.

- 12.** Lift the mainframe and insert the left and right tracks that extend from the rear of the mainframe into the ends of the tracks that you just extended. Make sure that the tracks mounted on the mainframe slip just inside the inner tracks that you extended earlier.
- 13.** Slide the mainframe back until it stops.
- 14.** Push to release the button latches, located on the outside of each track, and continue to slide the mainframe all the way back into the rack cabinet.
- 15.** Tighten the four screws that you left loose at the rear of the rack when you performed step 8, and pull the mainframe part way out of the rack. (Tighten the 10-32 screws using 28 inch-lbs of torque.)
- 16.** Be sure that the screws that you left loose at the front of the rack are loose enough to allow the slide-out track assemblies to seek the normal positions.
- 17.** Tighten the screws and push the mainframe all the way into the rack. If the tracks do not slide smoothly, readjust the level using the method described in steps 15 and 16. (Tighten the 10-32 screws using 28 inch-lbs of torque.)
- 18.** Install the proper power cord at the rear of the mainframe.

NOTE. To ensure the mainframe is properly mounted in the rack do not tighten the screws while installing the chassis track to the rack front rails. After all the mounting screws have been installed shift the mainframe to the far right of the rack, then tighten all the mounting screws. Refer to Figure 5 for screw positions. Depending on the rack manufacturer it may be necessary to use an additional spacer plate.

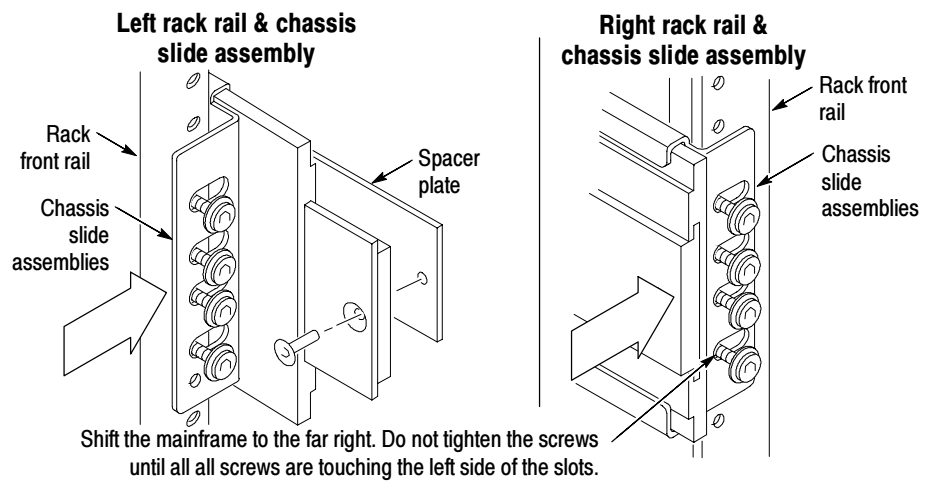

Figure 5: Rackmounting screw positions (front view).

Replaceable Parts

This section contains a list of the replaceable modules for the 020-2369-00 Rackmount Kit. Use this list to identify and order replacement parts.

Parts Ordering Information

Replacement parts are available through your local Tektronix field office or representative.

Changes to Tektronix products are sometimes made to accommodate improved components as they become available and to give you the benefit of the latest improvements. Therefore, when ordering parts, it is important to include the following information in your order.

- Part number (see Part Number Revision Level below)
- Instrument type or model number
- Instrument serial number
- Instrument modification number, if applicable

If you order a part that has been replaced with a different or improved part, your local Tektronix field office or representative will contact you concerning any change in part number.

Part Number Revision Level

Tektronix part numbers contain two digits that show the revision level of the part. For most parts in this manual, you will find the letters XX in place of the revision level number.

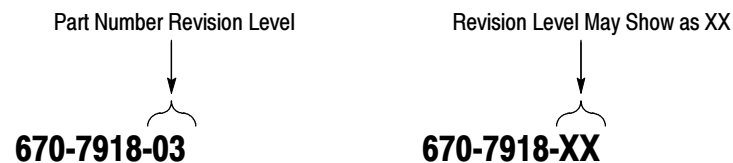

When you order parts, Tektronix will provide you with the most current part for your product type, serial number, and modification (if applicable). At the time of your order, Tektronix will determine the part number revision level needed for your product, based on the information you provide.

Using the Replaceable Parts List

This section contains a list of the mechanical and/or electrical components that are replaceable for the IntelliFrame Mainframe. Use this list to identify and order replacement parts. The following table describes each column in the parts list.

Parts List Column Descriptions

Column	Column name	Description
1	Figure & Index Number	Items in this section are referenced by figure and index numbers to the exploded view illustrations that follow.
2	Tektronix Part Number	Use this part number when ordering replacement parts from Tektronix.
3 and 4	Serial Number	Column three indicates the serial number at which the part was first effective. Column four indicates the serial number at which the part was discontinued. No entries indicates the part is good for all serial numbers.
5	Qty	This indicates the quantity of parts used.
6	Name & Description	An item name is separated from the description by a colon (:). Because of space limitations, an item name may sometimes appear as incomplete. Use the U.S. Federal Catalog handbook H6-1 for further item name identification.
7	Mfr. Code	This indicates the code of the actual manufacturer of the part.
8	Mfr. Part Number	This indicates the actual manufacturer's or vendor's part number.

Abbreviations Abbreviations conform to American National Standard ANSI Y1.1-1972.

Mfr. Code to Manufacturer Cross Index The table titled Manufacturers Cross Index shows codes, names, and addresses of manufacturers or vendors of components listed in the parts list.

Manufacturers cross index

Mfr. code	Manufacturer	Address	City, state, zip code
0KB01	STAUFFER SUPPLY CO	810 SE SHERMAN	PORTLAND, OR 97214-4657
06666	GENERAL DEVICES	PO BOX 39100	INDIANAPOLIS, IN 48239
TK1943	NEILSEN MANUFACTURING INC	3501 PORTLAND RD NE	SALEM, OR 97303
80009	TEKTRONIX INC	14150 SW KARL BRAUN DR PO BOX 500	BEAVERTON, OR 97077-0001

Replaceable parts list

Fig. & index number	Tektronix part number	Serial no. effective	Serial no. discont'd	Qty	Name & description	Mfr. code	Mfr. part number
6-0	020-2369-XX			1	COMPONENT KIT:RACKMOUNT KIT 1R, SILVER GRAY; TLA72X, TLA7XM	80009	0202221XX
-1	950-0991-00			2	HANDLE ALUMINUM BLK	80009	950099100
-2	212-0157-00			14	SCREW,MACHINE:8-32 X 0.5,FLH,100 DEG,STL CDPL,T-15	0KB01	ORDER BY DESC
-3	407-4524-00			1	BRACKET:LEFT,RACKMOUNT,SILVER GRAY	TK1943	407-4524-00
-4	212-0671-00			4	SCREW,MACHINE:10-32 X 0.625,FLH,100 DEG,STL,CD PL, TORX	0KB01	ORDER BY DESC
-5	407-4525-00			1	BRACKET:RIGHT, RACKMOUNT,SILVER GRAY	TK1943	407-4525-00
-6	351-1010-00			1	GUIDE:RACK SLIDE EXTENSION BRACKET,CLOSED SLOT,9.7 X 8.1 INCHES (PAIR)	06666	B-814-2
-7	351-0800-00			1	GUIDE,SLIDE:CHASSIS TRACK, (PAIR)	06666	CTS-124
-8	386-6999-00			1	PLATE,LEFT:OFFSET SPACER,16 X 1.45,0.062 THICK AL	TK1943	386-6999-00
-	071-0897-00			1	MANUAL TECH: INSTRUCTIONS, TLA72X, TLA7XM BENCHTOP MAINFRAME RACKMOUNT INSTALLATION, DP	80009	071-0897-00

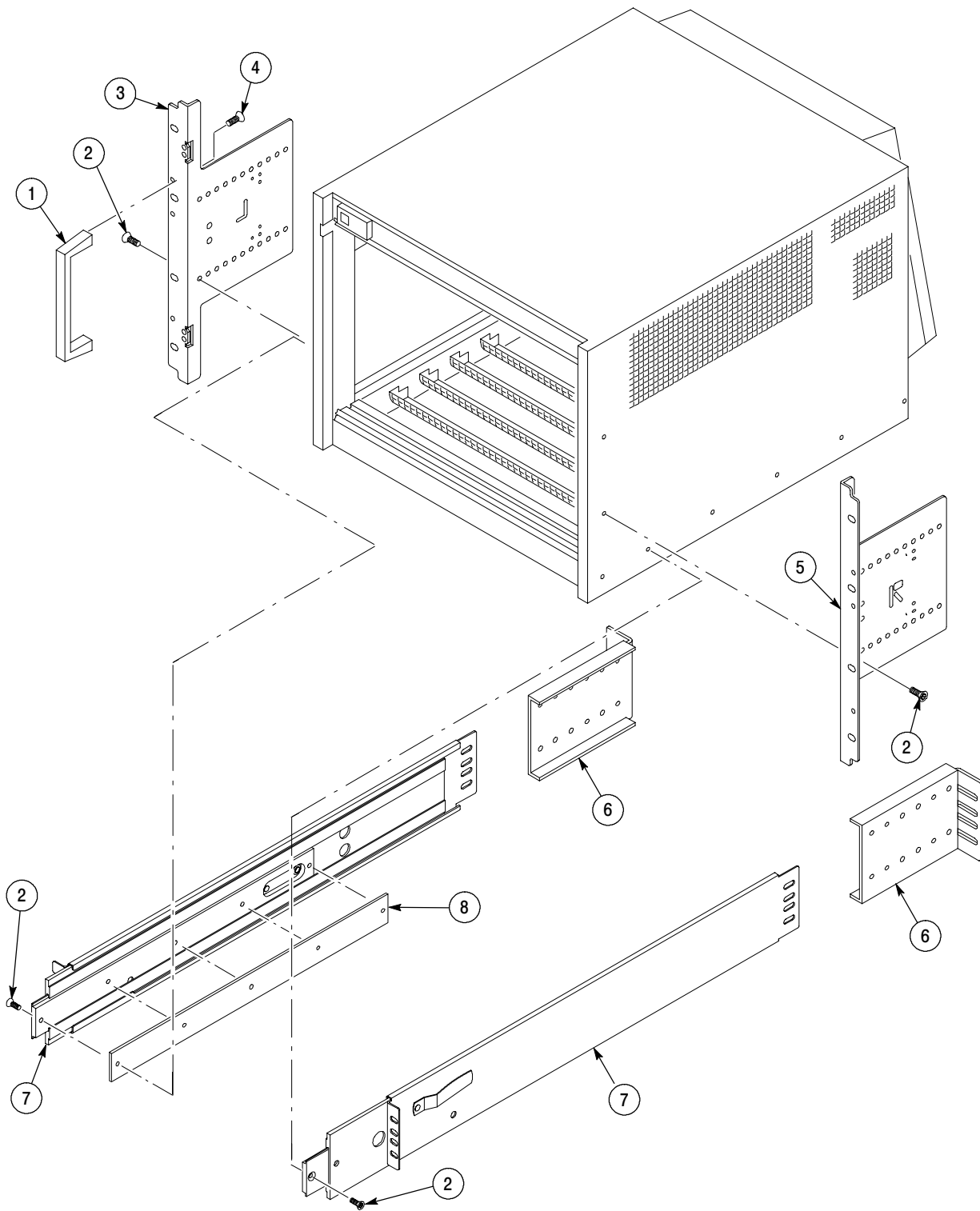

Figure 6: Rackmount assembly

